

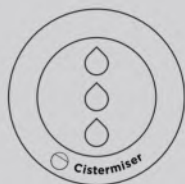

# Cistermiser



## Easyflush<sup>EVO</sup>

EVO 1.5"

EVO 2"

EVO CISTERN

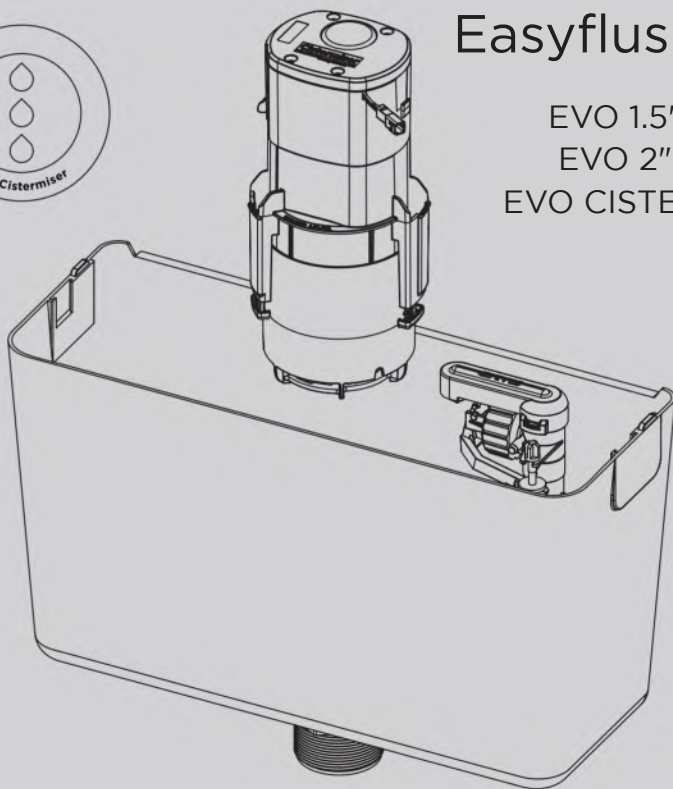

# 1. Introduction

Easyflush<sup>EVO</sup> is an infrared activated non-touch siphon WC flushing valve.

Available as a flush valve with a 1.5" or 2" outlet and as a flushing cistern. Non-touch activation via wave (default) or walkaway is configurable during installation.

## Supplied parts

### EVO 1.5" / EVO 2"

- 1 Outlet O-ring
- 2 Outlet
- 3 Outlet washer
- 4 Stem washer with boss
- 5 Outlet nut
- 6 Cap seal
- 7 Cap washer
- 8 Cap nut
- 9 Flush valve
- 10 IR Sensor unit
- 11 Sensor gasket
- 12 Sensor nut
- 13 Clamp plate
- 14 Screw packer
- 15 IR activation label walk & wave
- 16 Mains transformer
- 17 Clamp plate fixing screw
- 18 Mains transformer fixing screws
- 19 Battery case
- 20 Sticky pad

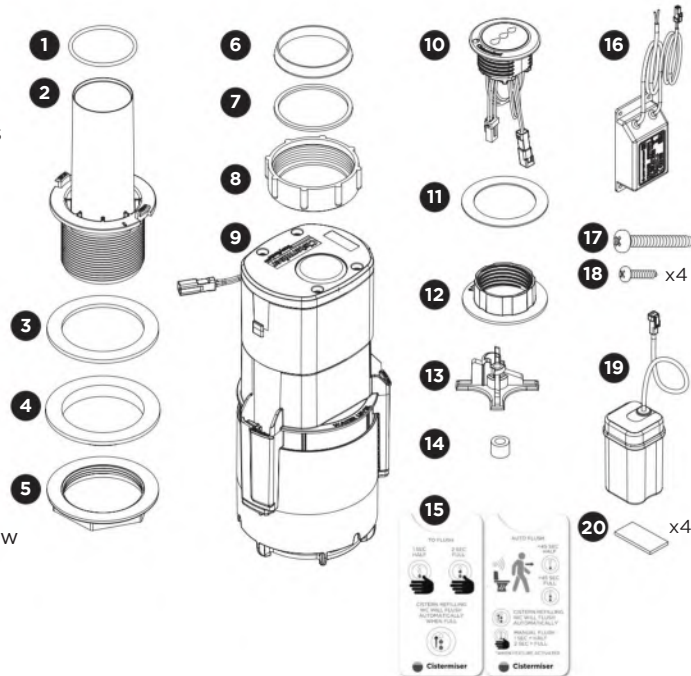

### EVO CISTERN

- 1 Outlet O-ring
- 2 Outlet
- 3 Outlet washer
- 4 Outlet nut
- 5 Cap seal
- 6 Cap washer
- 7 Cap nut
- 8 Flush valve
- 9 Cistern
- 10 Cistern lid
- 11 Flush pipe
- 12 Inlet Valve
- 13 IR Sensor unit
- 14 Sensor gasket
- 15 Sensor nut
- 16 Clamp plate
- 17 Screw packer
- 18 IR activation label walk & wave
- 19 Mains transformer
- 20 Clamp plate fixing screw
- 21 Mains transformer fixing screws
- 22 Battery case
- 23 Sticky pad

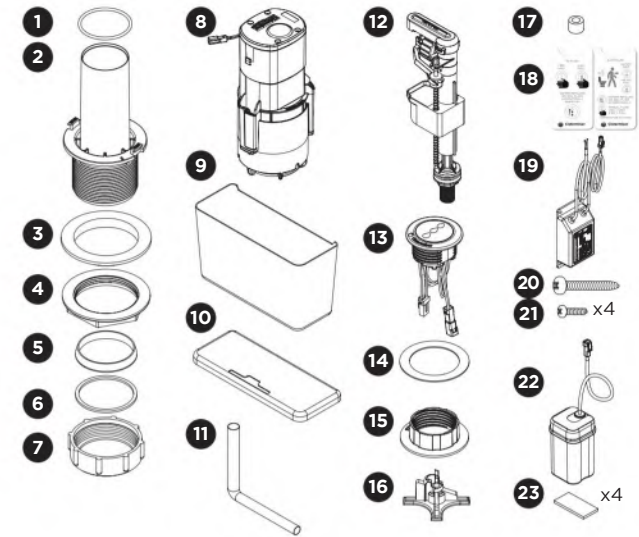

## Optional extras

- Remote Controller Programmer (ICU)
- Multi Product Power Supply Unit (PSUC)
- Side Front Adaptor (SFA)
- Easyflush<sup>EVO</sup> IFS extension cable 1.5m (IFS/10)

## 2. Valve Operation

Easyflush<sup>EVO</sup> is a siphonic flushing valve. When a flush is activated the spill over level is lowered below the water line initiating a siphon and flushing the cistern.

### Idle position

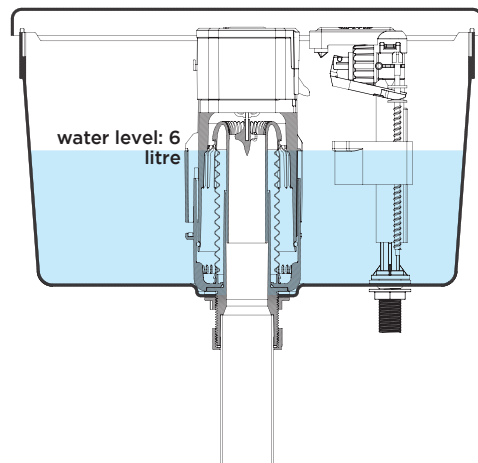

### Flush position

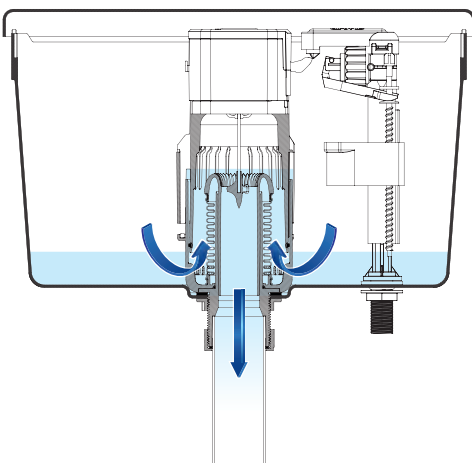

The flush is activated by the IR Sensor unit. This can be configured to flush on a wave (default) or flush when the user walks away:

### Wave (default):

#### To Flush

1 sec Wave = Half Flush    2 sec Wave = Full Flush



### Walk Away:

#### Auto Flush

Presence <45 sec = Half Flush

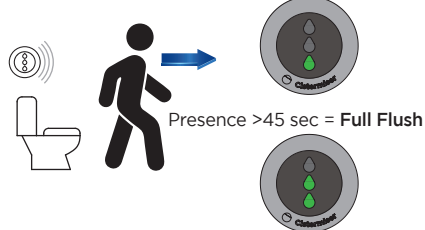

### Memory Flush:

If a flush is activated while the cistern is refilling, the sensor will remember the flush request and only activate when the cistern is full (to set refill time see page 13).

This is indicated by three rising green LEDs.

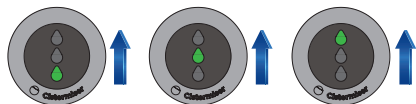

## 3. Valve Installation

Before commencing installation, isolate mains power supply and water supply.

Fit Cistern (Cistern supplied with EVO CISTERN only). Ensure cistern is mounted level.

Install Outlet fitting into Cistern.

Fit EasyFlush<sup>EVO</sup> Flush Valve to Outlet in cistern. Secure by rotating clockwise.

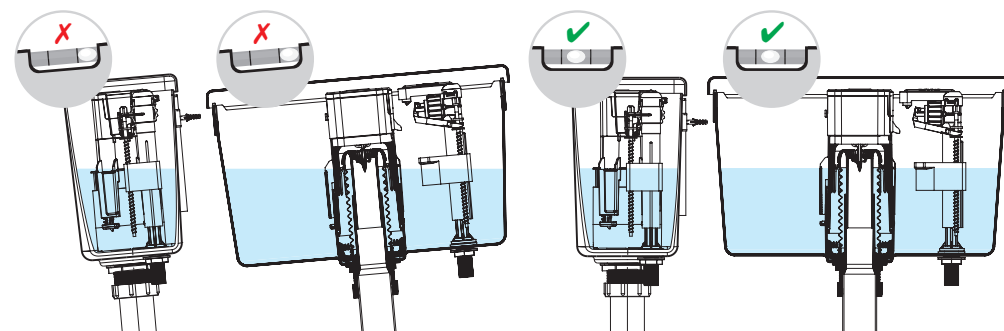
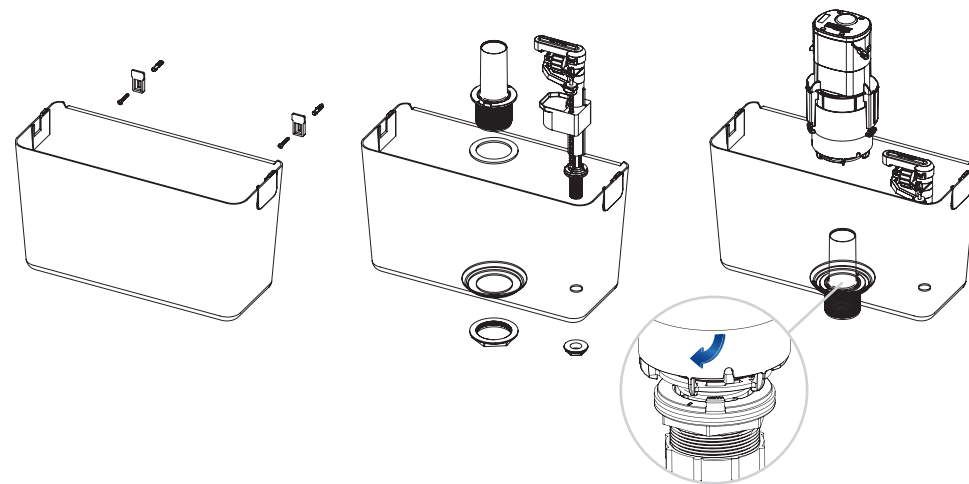

### WARNING:

Cistern must be level!  
All packaging must be removed after installation.



## 4. Easyflush<sup>EVO</sup> Valve Set up

Ensure the fill valve is adjusted so the water shuts off at the indicated water level on the flush valve. This is your full flush volume.

The height of the Easyflush<sup>EVO</sup> flush valve water level and the filling valve float level **must** be at the same height.

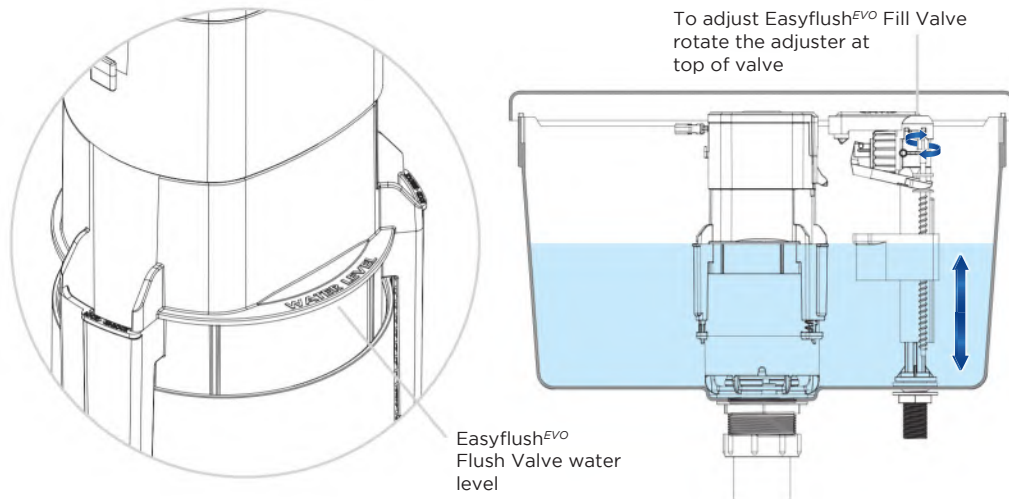

### Unlock

To adjust height of Easyflush<sup>EVO</sup> Flushing Valve rotate upper body clockwise to release.

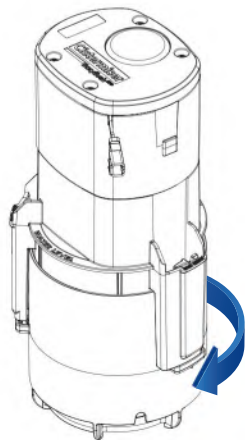

### Adjust

Lift or lower upper body to adjust height.

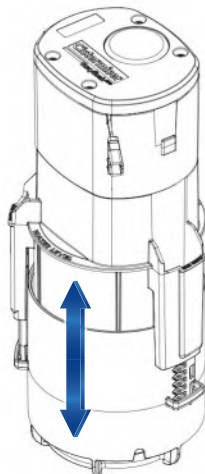

### Lock

Rotate anticlockwise to lock.

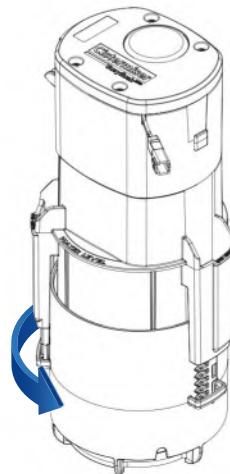

## 5. How to adjust the inlet valve if pressure is greater than 1 bar

Pre-assembled restrictor in the inlet valve is for water pressures below 1 bar. To change this to allow for higher pressures, the restrictor in the bottom of the valve will need swapping to the other restrictor supplied.

- 1 Loosen back nut and remove inlet valve from cistern.
- 2 Swap the restrictor part as necessary as per details in **Fig 1** below.
- 3 Place the inlet valve back through inlet hole with rubber washer inside the cistern.
- 4 Tighten the back nut.
- 5 Reconnect the water supply.
- 6 Adjust water level with grey adjusting screw.
- 7 Ensure connections are tight and secure.

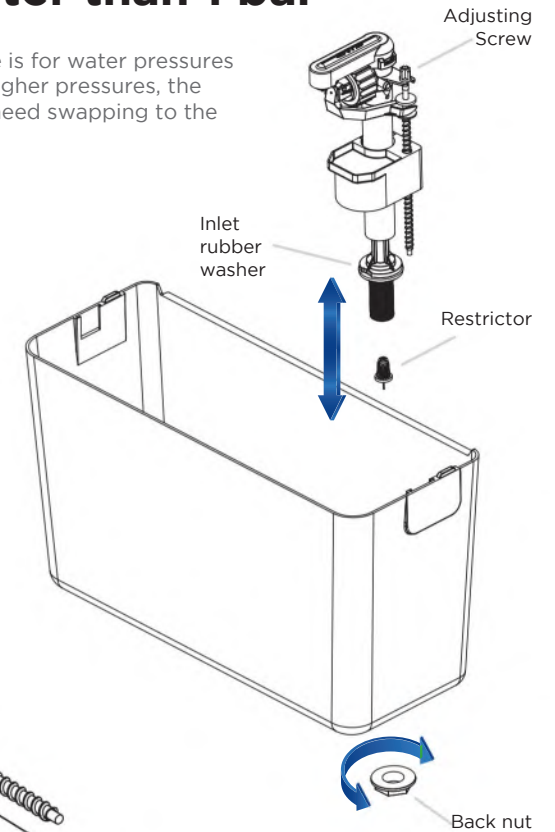
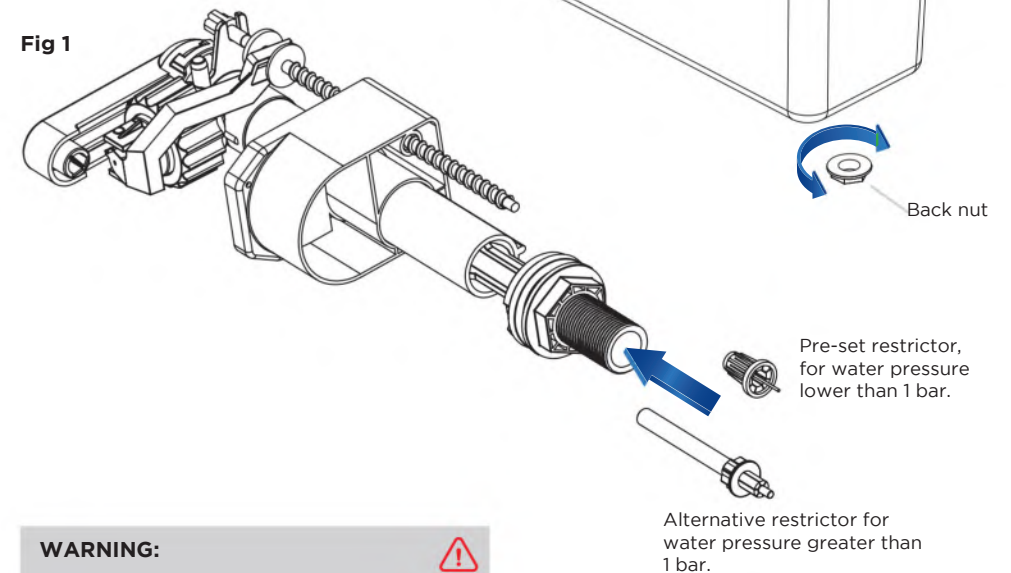

Fig 1



### WARNING:

Do not over tighten.  
Do not use any sealing paste or compound.





# 6. Sensor Positioning

Easyflush<sup>EVO</sup> can be operated by Wave activation (default) or Walkaway activation. The installed position of the sensor will depend on your flush activation setting (see below). Wave activation is the default setting and the WC will flush when the user's hand is placed in front of the sensor. Alternatively, with the Walkaway activation setting, the WC will automatically flush when the user leaves the cubicle.

See Config in section 12 to change the sensor activation from Wave to Walkaway.

### Exposed installation

Cistern mounted sensor (Wave activation only, default)

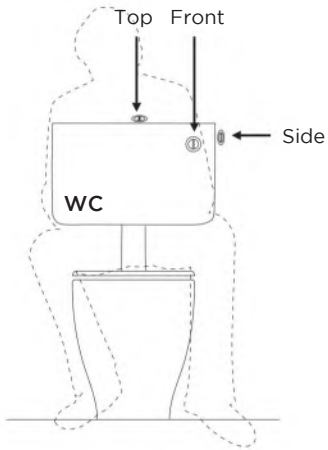

### Concealed installation

Panel mounted sensor (Wave activation only, default)

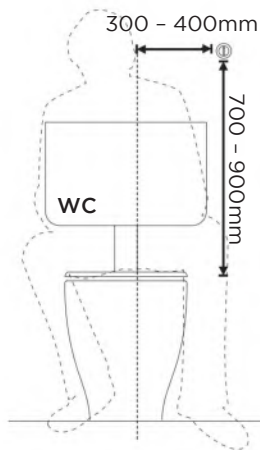

### Concealed installation

Panel mounted sensor (Walkaway activation only)

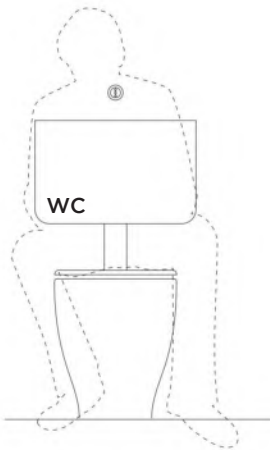

Drill hole to the required diameter (refer to page 8).

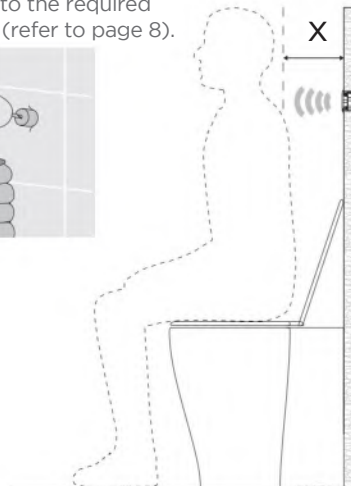

#### NOTES:

Do not position sensor near toilet roll holder or grab rail.

Reflective surfaces and materials such as hi-vis jackets may cause the sensor to activate unexpectedly.

**Walkaway version only.** Minimum distance applies. If x (see diagram) is less than 12cm it is recommended that the Hand Activation is disabled. Refer to section 12.

# Panel mounted sensor installation

### Thin wall

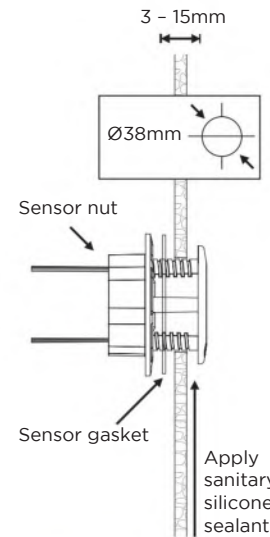

### Medium thickness wall

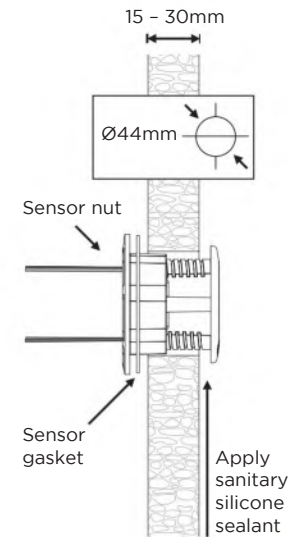

### Thick wall

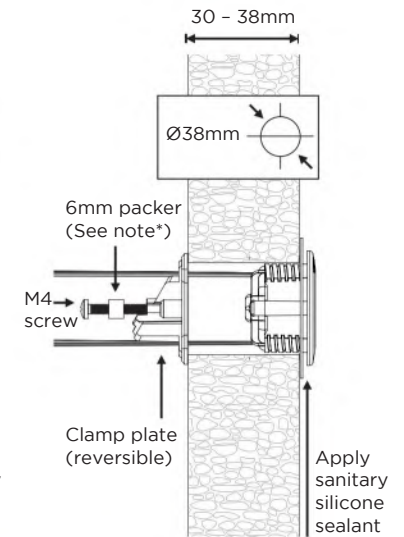

#### NOTE:

\*If wall thickness is under 32mm use packer to prevent screw causing damage to sensor

## Cistern mounted sensor - Wave version only

### Sensor fixing

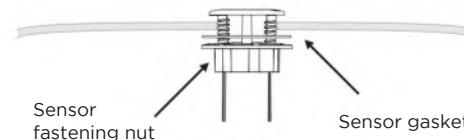

### Mounting options

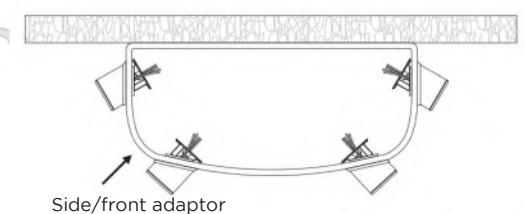

#### NOTE:

For holes between 40 and 50mm contact Cistermiser for a hole adaptor. A hole diameter larger than 50mm is a non standard installation.

#### NOTE:

Side/front adaptor required. Not supplied with standard product but available as an extra. Contact Cistermiser for further details or order online at [www.cistermiser.co.uk](http://www.cistermiser.co.uk)

## 7. Power Connections

Isolate mains power supply before proceeding. Mains wiring should be undertaken by a competent person.

Battery Case – Open case and fit 4 x AA (LR-6) batteries. Use fittings provided or clip onto Easyflush<sup>EVO</sup> Flush Valve.

Mains Adaptor – Fasten on a panel in a dry location using screws or sticky pads provided. Connect the un-terminated cable to a 50Hz 230V AV single phase supply via a 1A fused spur (not supplied).

### NOTE:

Always connect Sensor to Flush Valve before connecting power.

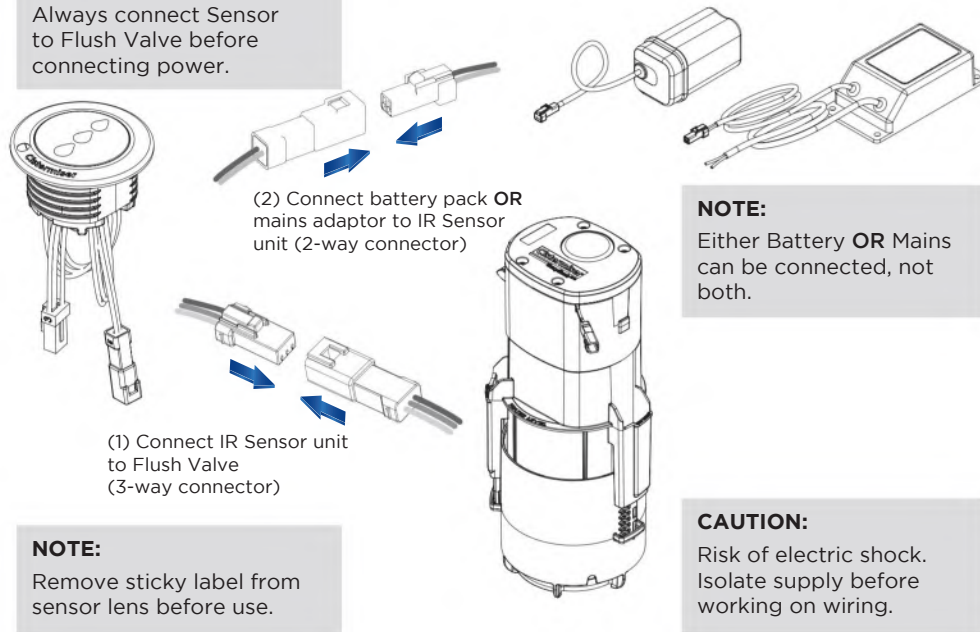

## Multiple power connections for Easyflush<sup>EVO</sup>

If installing multiple Cistermiser products, the PSUC Multi Product Power Supply Unit is available as an accessory. Contact Cistermiser for more details.

Multi product power supply unit (Not supplied, contact Cistermiser for further details). Suitable for powering up to 10 Easyflush<sup>EVO</sup> units.



## 8. Testing and Commissioning

Ensure flush valve and fill valve are set to the same height level (see page 6) so the water level is at the mark on the Flush valve.

Ensure cistern is level and check for leaks.

Activate flush via sensor or manual override to verify operation.

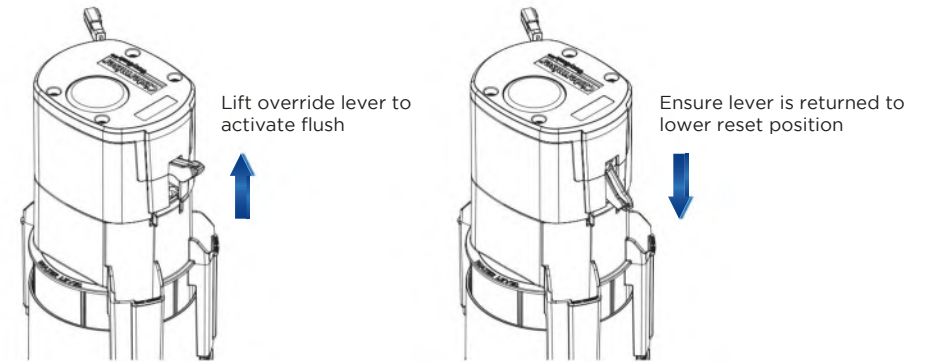

## Sensor LED Glossary

<b>Sensor Uncalibrated -</b> 1 <b>red</b> LED flash 4 times per second		<b>Full Flush via Wave or Walkaway -</b> 2 <b>green</b> LEDs flash once per second	
<b>Servo Failure (Call Cistermiser for advice) -</b> 2 <b>red</b> LEDs flash once per second		<b>Partial Flush via Wave or Walkaway -</b> 1 <b>green</b> LED flash once per second	
<b>Vandal Fault -</b> 3 <b>red</b> LEDs flash once per second		<b>Body Seen (Walkaway) -</b> 1 <b>green</b> LED flash once every 3 seconds	
<b>Low Battery Fault -</b> 1 <b>red</b> LED flash once per second		<b>Flush requested -</b> 3 <b>green</b> LEDs refilling	

\* **Amber** LED = Configuration

### NOTE:

**For chemical water treatment.** If the water system has been treated with chemical dosing, ensure the system is thoroughly flushed before fitting any Cistermiser products. Concentrated chemicals in dead legs can damage the product and result in failure. If the water is treated with Chlorine Dioxide (ClO<sub>2</sub>), ensure concentration levels are maintained below 5ppm.

## 9. Maintenance

Fill valve (supplied with EVO CISTERN only): Periodically rinse the inlet filter and valve diaphragm. If the diaphragm is damaged contact Cistermiser for a replacement.

You may rinse the filter or the membrane to maintain your fill valve.

If the membrane is damaged, you need to replace it.

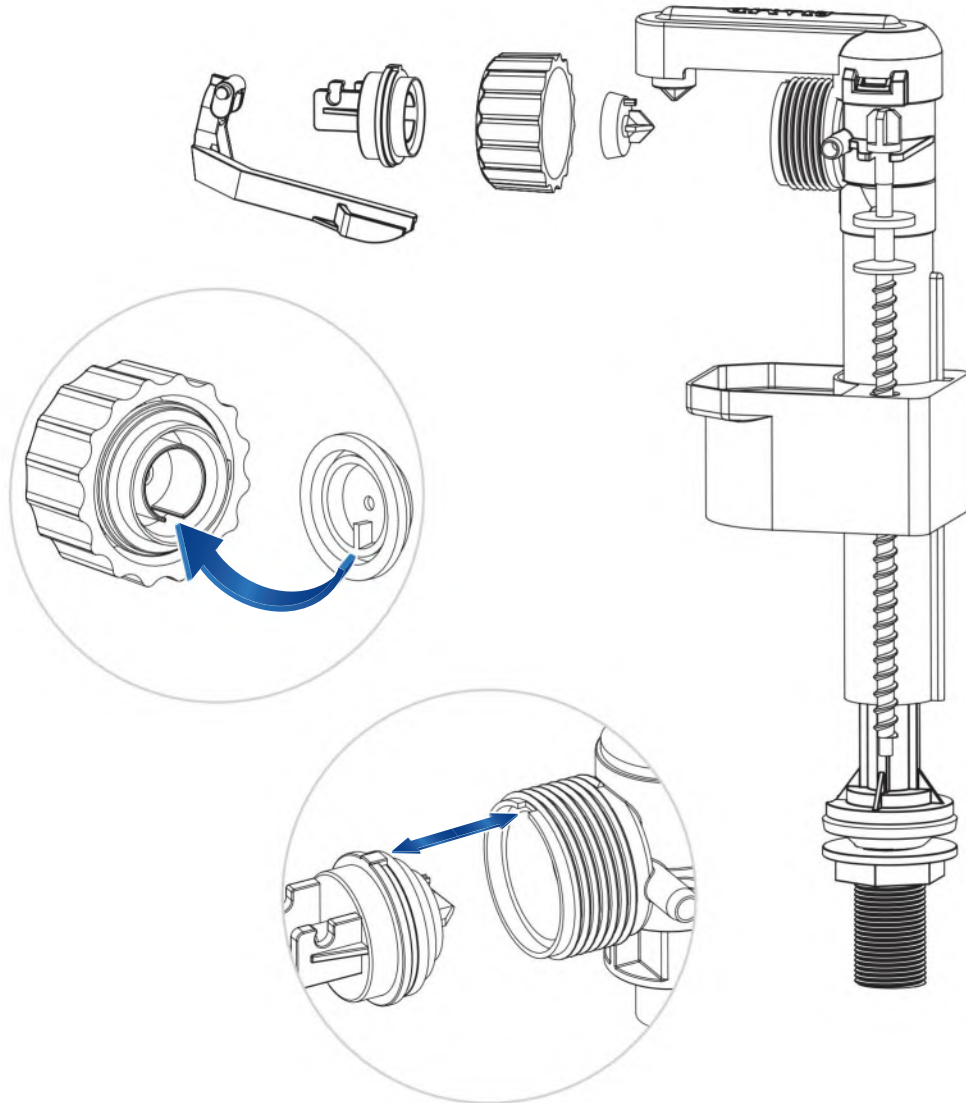

## 10. Usage advice and specification

### Factory settings

Range (EF Wave):	~10cm
Range (EF Walkaway):	~55cm (~6cm for hand activation)
Refill duration after part flush:	40 seconds
Refill duration after full flush:	60 seconds
Part flush duration:	2¾ seconds
Full flush duration:	6 seconds
Power requirements:	Either 6V from 4 x alkaline AA (LR6) batteries or 6V DC regulated from mains adaptor (1A fused spur required)
Normal battery life:	27 000 cycles
Cleaning:	Clean with soap and water only
Lens care:	Infrared lens can be polished with a soft cloth

### Electronic specification

Control classification:	Independent
Maximum load:	1A (6W) at 6VDC
Rated temperature range:	0-40 °C
Mains power supply:	100-250V AC 50/60Hz 1A MAX

### Fill Valve (supplied with EVO CISTERN only)

Minimum working pressure:	0.1 bar
Maximum working pressure:	10 bar

# 11. Component dimensions

## EVO 1.5" & EVO 2"

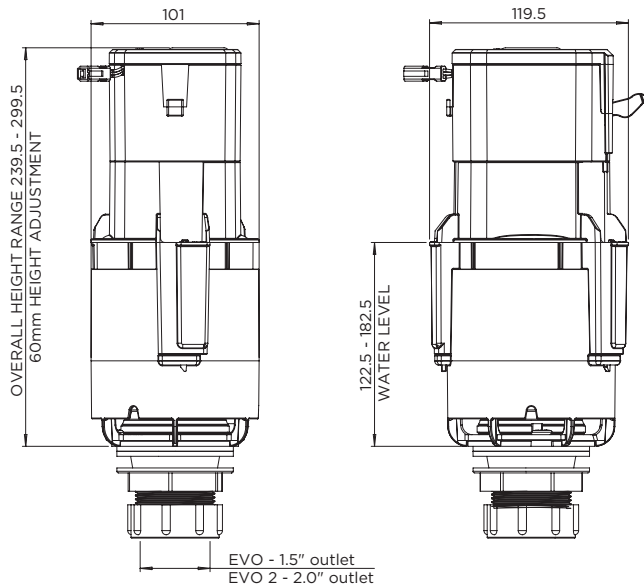

## EVO CISTERN

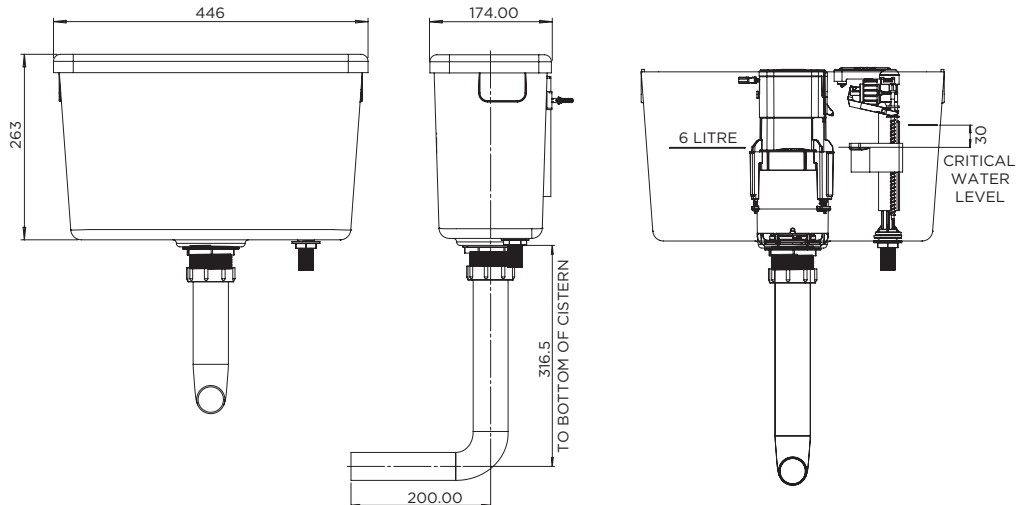



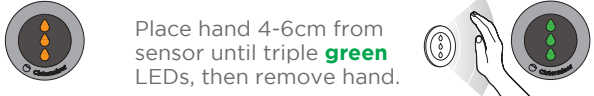

# 12. Advanced settings guide



Carry out only if settings need to be changed.

- 1 Disconnect power, wait for 5 seconds and reconnect.
- 2 When flashing triple **amber**. Place hand 4-6cm from sensor until triple **green** LEDs, then remove hand. 
- 3 **You are now in configuration mode**  
If a hand is not placed over the sensor, it will go into normal operation mode.



### Wave/walkaway mode switching (this will restore default settings)

- A Wait for 1 x triple **red** LEDs to enter wave/walkaway setting  X1
- B During the triple **red** flash briefly place your hand in front of the sensor. The sensor will flash one central **green** LED to indicate wave function, to change function put your hand in front of the sensor for 3 seconds. 
- C Sensor will flash single central **green** LED for wave mode  or double top/bottom **green** LEDs for walkaway mode 

### Wave sensing range adjustment (when Wave variant is selected)

- A Wait for 2 x triple **red** LED to enter sensing range mode.  X2
- B Briefly place your hand in front of the sensor until the **green** LED flashes slowly. Range configuration mode will then be ready. 
- C Move your hand to the distance from the sensor you would like to set as maximum range. Wait 8 seconds until constant triple **green** LEDs show.  Sensor distance is now set.

### Walkaway sensing range adjustment (when Walkaway variant is selected)

- A Wait for 2 x triple **red** LEDs to enter sensing range mode.  X2
- B Briefly place your hand in front of the sensor until triple **green** LEDs flash slowly. Range configuration mode will then be ready. 
- C Stand at the distance from the sensor you would like to set as maximum range. Wait 8 seconds until constant triple **green** LEDs show.  Sensor distance is now set.



# 13. Infrared Configuration Unit (ICU) guide

**NOTE:** Not supplied but available from Cistermiser or any major plumbing merchant.

## Full flush duration adjustment

- A** Wait for 3 x triple **red** LEDs to enter flush duration.
- B** During the triple **red** flashing briefly place your hand in front of the sensor. The valve will start to flush and triple **green** flashing LEDs will be seen. HOLD HAND STEADY.
- C** When the valve has flushed for the desired full flush time, move your hand out of the line of sight of the sensor and triple **green** LEDs will show. The water will cease to flow and the full flush time will be set.

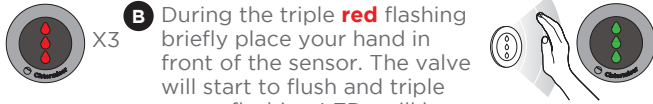

### NOTE:

Part flush is automatically set to approximately 2/3 of full flush

## Refill duration adjustment

- A** Wait for 4 x triple **red** LEDs to enter refill time.
- B** During the triple **red** flashing, briefly place your hand in front of the sensor. The valve will flush and the cistern will refill. Triple **green** flashing LEDs will be seen.
- C** Once the cistern has refilled completely and the water has ceased to flow, move your hand back into the line of sight of the sensor and triple **green** LEDs will show. The refill time has now been set.

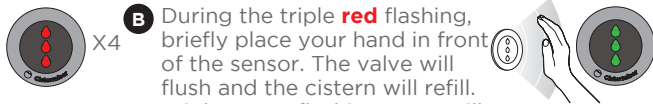

- 4** After configuration the LEDs will flash triple **amber**, giving opportunity to re-enter configuration mode.



## Button descriptions

- C** Activates cleaning mode
- Activates ICU configuration mode
- Decreases setting
- Increases setting
- OK** Checks the setting being altered
- SAVE** Saves changes and exits ICU configuration mode
- QUIT** Quits ICU configuration mode without saving changes
- 1** Configures sensor range
- 2** Configures full/part flush time
- 3** Configures cistern refill time
- 4** Toggles Wave function ON/OFF (Walkaway ONLY)
- 5** 12-hour hygiene cycle activation
- 6** Dual flush activation
- 7** Autorange setting of sensor range
- 8** No function
- 9** Switch Wave & Walkaway variants & resets to default factory settings

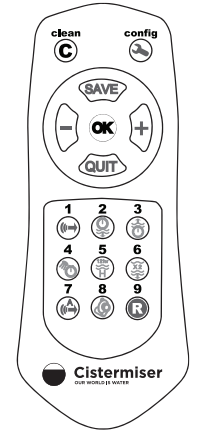

## Entering configuration mode

Point the ICU towards the Easyflush<sup>FVO</sup> sensor and press the configuration button, LEDs will flash **amber**. Activation is most effective when the configuration button is held down as the ICU is brought close to the sensor.

It can take up to 3 seconds for the product to sense the ICU. The Easyflush<sup>FVO</sup> will return to normal operation if there are no button presses for 30 seconds.

## Configuring sensor range

Point the ICU at the Easyflush<sup>FVO</sup> sensor and press the **1** sensor range button (the sensor blinks **green**).

Decrease or increase the sensor range by pressing the and buttons respectively. The sensor blinks red when the min or max value is reached.

Press the **OK** button to check the sensor range setting - the sensor displays the current setting by flashing **green**; see table.

### For Wave version

Number of flashes	1	2	3	4	5
Range (cm approx)	5	10	15	20	25

### For Walkaway version

Number of flashes	1	2	3	4	5
Range (cm approx)	45	50	55	60	65

Save setting and exit ICU configuration mode by pressing **SAVE** the button.

Exit without saving by pressing the **QUIT** button.

## Configuring Full/Part flush time

Point the ICU at the Easyflush<sup>EVO</sup> sensor and press the **2** (🕒) flush time button (the sensor blinks **green**).

Decrease or increase the flush time by pressing the ⏪ and ⏩ buttons respectively. The sensor blinks **red** when the min or max value is reached.

Press the **OK** button to check the flush time setting - the sensor displays the current setting by flashing **green**; see table.

Number of flashes	1	2	3	4	5
Full flush time (sec)	2¼	3	4	5½	8
Part flush time (sec)	1½	2	2¾	3¾	5½

Save setting and exit ICU configuration mode by pressing the **SAVE** button.

Exit without saving by pressing the **QUIT** button.

## Configuring refill time

Point the ICU at the Easyflush<sup>EVO</sup> sensor and press the **3** (🕒) refill time button (the sensor blinks **green**).

Decrease or increase the refill time by pressing the ⏪ and ⏩ buttons respectively. The sensor blinks **red** when the min or max value is reached.

Press the **OK** button to check the refill time setting - the sensor displays the current setting by flashing **green**; see table.

Number of flashes	1	2	3	4	5	6	7
Refill time (sec)	0	20	40	60	80	100	120

Save setting and exit ICU configuration mode by pressing the **SAVE** button.

Exit without saving by pressing the **QUIT** button.

## Hand wave flushing (walkaway mode only) activation and de-activation

Point the ICU at the Easyflush<sup>EVO</sup> sensor and press the **4** (👋) (the sensor blinks **green**). By default the hand wave function is on.

Pressing the ⏪ and ⏩ button switches the hand wave function on or off respectively.

Press the **OK** button to check the setting - the sensor flashes **green** once if function is off or twice if it is on.

Save setting and exit ICU configuration mode by pressing the **SAVE** button.

Exit without saving by pressing the **QUIT** button.

## 12 hour hygiene flush activation and de-activation

Point the ICU at the Easyflush<sup>EVO</sup> sensor and press the hygiene cycle button (the sensor blinks **green**).

Pressing the ⏪ and ⏩ buttons switches the hygiene flush function on or off respectively.

Press the **OK** button to check the setting - the sensor flashes **green** once if function is off or twice if it is on.

Save setting and exit ICU configuration mode by pressing the **SAVE** button.

Exit without saving by pressing the **QUIT** button.

## Dual flush activation and de-activation

Point the ICU at the Easyflush<sup>EVO</sup> sensor and press the **6** (👉) (the sensor blinks **green**).

Pressing the ⏪ and ⏩ buttons switches the dual flush function on or off respectively. Press the **OK** button to check the setting - the sensor flashes **green** once if function is off or twice if it is on.

Save setting and exit ICU configuration mode by pressing the **SAVE** button.

Exit without saving by pressing the **QUIT** button.

## Configuring sensor range using the autorange function

If the cubicle door is opposite the sensor, ensure that the cubicle door is closed or ajar, but not fully open.

Point the ICU at the Easyflush<sup>EVO</sup> sensor and press the **7** (👤) button.

Immediately stand clear of the sensor. Sensor blinks **green** for 5 seconds, then a steady **green** when setting complete. The sensor measures the background reflections and sets the sensor range to an appropriate setting.

Save setting and exit ICU configuration mode by pressing the **SAVE** button.

Exit without saving by pressing the **QUIT** button. Only possible when configured as Walkaway.

## Wave/walkaway conversion

Point the ICU at the sensor and press the **9** (👤) button (the sensor blinks **green**).

Pressing the ⏪ and ⏩ button switches the function to Wave and Walkaway respectively. Press the **OK** button to check the setting - the sensor flashes **green** once if wave or twice if walkaway.

Save setting and exit ICU configuration by pressing the **SAVE** button.

Exit without saving by pressing the **QUIT** button.

# 14. Frequently asked questions

Refer to section 7 Testing and Commissioning for normal sensor function indicators after user activation

## No water is entering the cistern

<b>No obvious indicator</b>	Ensure that the water supply is connected and the fill valve is operating correctly. Check filters for blockages.
<b>The sensor is covered</b>	Anti-vandal mode has been triggered. The object/debris needs to be removed from the sensor and the valve will resume normal functionality.

## Flush valve not activating

<b>The sensor light does not flash when a hand is placed in front of it.</b>	Ensure the power supply is connected. If mains power is being used through the mains adaptor check that the mains adaptor is working by reverting to the battery pack. Remove the mains adaptor when using batteries.
<b>Sensor is flashing single top red LED slowly, or not at all when a hand is placed in front of it.</b>	Low or no battery power; change batteries. If operated by mains power, check wiring then contact Cistermiser.
<b>Sensor LEDs OK</b>	Check fill valve and flush valve are aligned with water level. Ensure cistern is level. Check manual activation lever is down (neutral position).
<b>Flush volume is too low</b>	Ensure full flush time is correct (default 3 seconds), so all water is flushed from the cistern. Refer to Easyflush <sup>EVO</sup> Valve set up (section 4). Adjust flush valve and fill valve height to change full flush volume.

## Continuous flow into the pan from the cistern

<b>No obvious indicator</b>	Water flowing through the overflow; ensure that the water entering the cistern is being shut off by adjusting the float accordingly. If the float is set too high, water will continuously flow into the cistern and out of the overflow.
-----------------------------	---

## WC flushes when in use

<b>Working as normal otherwise</b>	<p>Ensure that the sensor is mounted in the correct position. Refer to the Sensor positioning (section 6).</p> <p>Ensure the sensor range is correctly configured. Refer to the advanced setting guide (section 12).</p>
------------------------------------	--

## Other issues

<b>Sensor flashing red middle LED 4 times per second</b>	Sensor uncalibrated. Call Cistermiser for advise.
<b>Sensor flashing single red top LEDs</b>	Low or no battery power. Change batteries. If operated by mains power, check wiring then contact Cistermiser.
<b>Sensor flashing triple red LEDs</b>	Sensor covered or heavily scratched. Uncover or polish out scratches.
<b>Sensor flashing double red top LEDs</b>	Servo motor obstruction or wiring fault - Call Cistermiser for advice.

## Cistermiser product warranty and extended warranty

Cistermiser products are guaranteed for 12 months from the date of manufacture. The guarantee is for faulty products and parts only; there is no labour warranty. If you believe your product is faulty, please either contact Cistermiser directly on 0118 969 1611 or at [support@cistermiser.co.uk](mailto:support@cistermiser.co.uk), with a photograph and the serial number to help diagnose the cause of the problem.

The warranty on Cistermiser products can be extended within one year of date of manufacture, at no cost, to three years from the date of installation (see details on page 20). Please make a note of the serial number and take a photograph of the installation before you leave site.

# Commissioning check-list Easyflush<sup>EVO</sup>

**3 YEAR**  
extended  
warranty

The warranty on Cistermiser products can be extended within one year of date of manufacture, at no cost, to three years from the date of installation. Once the valve has been installed, complete the product commissioning checklist below to demonstrate compliance with the installation instructions. Email a photograph of this completed form to [warranty@cistermiser.co.uk](mailto:warranty@cistermiser.co.uk) or post to **Cistermiser, Unit 1, Woodley Park Estate, 59-69 Reading Road, Woodley, Berks, RG5 3AN.**

Product serial number .....

Installation address .....

No	Activity	Checked	Date
1.	Ensure the cistern is installed level (check with spirit level).	<input type="checkbox"/>	<input type="checkbox"/>
2.	Ensure the Flush Valve height is set to give the correct flush volume. Ensure the Fill Valve float height is adjusted so the water line is level with the indicator on the Flush Valve.	<input type="checkbox"/>	<input type="checkbox"/>
3.	Ensure water supply is activated. For EVO CISTERN 0.1 - 10 bar.	<input type="checkbox"/>	<input type="checkbox"/>
4.	Check sensor is mounted in correct position (refer to section 6).	<input type="checkbox"/>	<input type="checkbox"/>
6.	Ensure label is removed from sensor before connecting power.	<input type="checkbox"/>	<input type="checkbox"/>
7.	Check power connections (refer to section 7).	<input type="checkbox"/>	<input type="checkbox"/>
8.	Ensure either mains or battery power or multi product power supply is connected.	<input type="checkbox"/>	<input type="checkbox"/>
9.	Check sensor range, refill time, full flush times are suitable for installation (refer to advanced settings guide section 12).	<input type="checkbox"/>	<input type="checkbox"/>
10.	Test operation.		
a	Wave: Place hand within -10cm of sensor for 1 second = valve will part flush and the sensor will flash the single green LED once per second. Place hand within 10cm of sensor for two seconds = valve will full flush and the sensor will flash the double bottom green LEDs once per second.	<input type="checkbox"/>	<input type="checkbox"/>
b	Walkaway: If presence is detected, sensor flashes green once every three seconds. When sensor detects a presence for less than 45 seconds, valve will part flush. Where sensor detects a presence for over 45 seconds valve will full flush.	<input type="checkbox"/>	<input type="checkbox"/>





# Davidson Holdings' brands

## Salamander Pumps

**Salamander** is one of the UK's leading manufacturers of pumps for boosting water pressure for showers, bathrooms and whole house supply in domestic and small commercial tank-fed systems.

[salamanderpumps.co.uk](http://salamanderpumps.co.uk)

## Talon®

**Talon** is the UK market leader in the manufacture and supply of plastic pipe clips, pipe collars and fixing plugs, plus a range of cover profiles for concealing pipework.

[talon.co.uk](http://talon.co.uk)



**Keraflo**  
OUR WORLD IS WATER

**Keraflo** manufacture delayed action float valves, which provide an accurate and effective method of controlling the level of stored cold water in tanks both with and without raised float valve chambers. The range is used in domestic, commercial and industrial applications worldwide.

[keraflo.co.uk](http://keraflo.co.uk)



**Combimate**  
GUARANTEED LIMESCALE PREVENTION

**Combimate** is a domestic limescale prevention device that prevents limescale build-up and soft water corrosion in combination boilers and other domestic hot water appliances.

[combimate.co.uk](http://combimate.co.uk)

## Cistermiser Limited

Unit 1, Woodley Park Estate, 59-69 Reading Road,  
Woodley, Reading, Berkshire RG5 3AN

**t:** +44 (0) 118 969 1611

**e:** [sales@cistermiser.co.uk](mailto:sales@cistermiser.co.uk)

**[cistermiser.co.uk](http://cistermiser.co.uk)**

A Davidson Holdings company

