

Vecta+ Sensor Tap Range



The Vecta+ Sensor Tap range provides the optimum in high hygiene standards for the modern-day commercial washroom, through their non-touch, infrared control activation. This reduces the risk of cross contamination, while reducing water usage, increasing efficiency, saving energy and minimising costs.

This range is packed with safety features, including a safety shut off, which automatically activates after 60 sec of continual water flow and a smart shut-off which will respond to a power outage, by preventing the water flow, minimising the risk of flooding.

The Vecta+ Sensor Tap range are available in stylish chrome and are easy to install, as retrofit or new build installations. The highly intelligent electronics, safeguard against misuse and vandalism, while offering an unwavering reliability which is required within a commercial washroom environment.

Key features and benefits

- **Save** - up to 80% of water compared to a conventional one handed lever mixer tap
- **Improved hygiene** - reduce the risk of cross contamination
- **Non-touch** - Intuitive and easy to use. These non-touch solutions are more hygienic and reduce the risk of cross contamination
- **Water and energy saving** - the water only runs when your hands are within range, so less water to heat. Water saving and energy efficient is more cost effective
- **Easy to install and maintain** - chrome finished, easy to retrofit and swap out existing manual taps. External solenoid for easier servicing, VST and VSS only.
- **Mains and battery power** - options out of the box
- **Safety shutoff** - after 60 seconds of continuous water activation, the tap will automatically shutoff the flow of water to reduce the risk of flooding
- **Smart shutoff** - in the event of a power outage the device will automatically shut out the water flow to reduce the risk of flooding
- **Support** - environmental building schemes
- **Ease of use** - for elderly or people with reduced mobility



3 YEAR
extended
warranty

Vecta+ Sensor Spout - VSS

Wall / panel mounted pre-mixed supply basin tap, with infrared sensor for hygienic hands-free, non-touch operation, mains or battery powered external valve and 3.5 or 5.0 litre per minute flow rate options

Technical information

- **Dimensions** 243mm W x 38mm H x 38mm D, Spray nozzle height above basin surface (variable, see installation guide), Spray nozzle projection from tap body 207mm
- **Mounting requirements** Any horizontal surface up to 40mm in thickness, requires a hole of 26-32mm in diameter
- **Sensor range** Up to 18cm
- **Run-on time** 2 seconds
- **Power requirements** 6V DC from 4 x alkaline AA (LR6) batteries or 6V DC regulated from mains adaptor (1A fused spur required)
- **Normal Battery life** 300,000 activations (flashing LED indicates batteries are low and need to be replaced)
- **Ambient temperature range** Operating: 0 to 40°C, Storage: -25 to 40°C

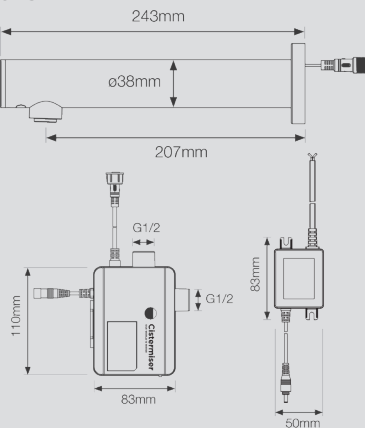

Vecta+ Sensor Tap - VST

Deck-mounted pre-mixed supply basin tap, with infrared sensor for hygienic hands-free, non-touch operation, mains or battery powered external valve and 3.5 or 5.0 litre per minute flow rate options

Technical information

- **Dimensions** 150mm W x 133mm H x 47mm D, Spray nozzle height above basin surface 111mm, Spray nozzle projection from tap body 83mm
- **Mounting requirements** Any vertical surface up to 40mm in thickness, requires a hole of 28-32mm in diameter
- **Sensor range** Up to 18cm
- **Run-on time** 2 seconds
- **Power requirements** 6V DC from 4 x alkaline AA (LR6) batteries or 6V DC regulated from mains adaptor (1A fused spur required)
- **Battery life** 300,000 activations (flashing LED indicates batteries are low and need to be replaced)
- **Ambient temperature range** Operating: 0 to 40°C, Storage: -25 to 40°C

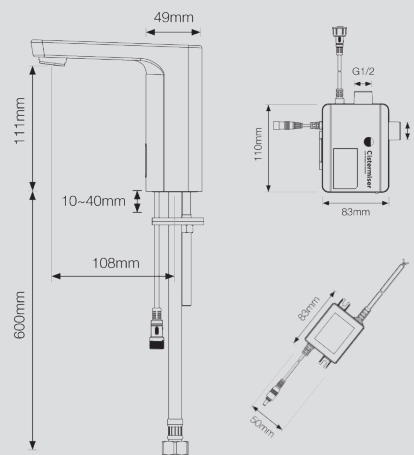

Vecta+ Sensor Mixer Tap - VSMT

Deck-mounted dual supply basin tap, with infrared sensor for hygienic hands-free, non-touch operation, mains or battery powered internal valve and 3.5 or 5.0 litre per minute flow rate options

Technical information

- **Dimensions** 150mm W x 133mm H x 47mm D, Spray nozzle height above basin surface 111mm, Spray nozzle projection from tap body 83mm
- **Mounting requirements** Any horizontal surface up to 40mm in thickness, requires a hole of 28-32mm in diameter
- **Sensor range** Up to 18cm
- **Run-on time** 2 seconds
- **Power requirements** 6V DC from 4 x alkaline AA (LR6) batteries or 6V DC regulated from mains adaptor (1A fused spur required)
- **Battery life** 300,000 activations (flashing LED indicates batteries are low and need to be replaced)
- **Ambient temperature range** Operating: 0 to 40°C, Storage: -25 to 40°C

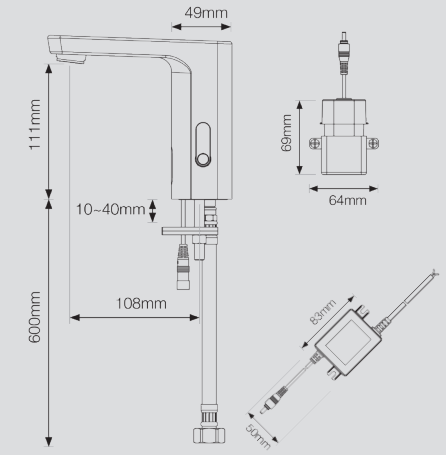

Installation

- Operating pressure: 0.5bar - 6bar
- Power: Battery and Mains options included as standard out of the box.
- Also available as an optional extra is an Multi-Product Power Supply Unit (PSUC) which can provide power for up to 20 taps, with only 1 fused spur required (additional costs apply).
- Pipe fitting requirements (inlet and outlet diameter): 15mm G1/2

Regulatory and Compliance

- WRAS: Approved
- BREEAM: Wat 1 (3.5lpm fitted, 5lpm in the box)
- European water label

Additional Parts / Optional Extras (additional costs apply)

- Multi Product Power Supply Unit (PSUC)
- Copper inlet tube

Cistermiser Limited

Unit 1 Woodley Park Estate, 59-69 Reading Road, Woodley, Reading, Berkshire RG5 3AN. Cistermiser is a subsidiary of Davidson Holdings Ltd. Cistermiser Ltd reserves the right to amend images and specification without prior notice.

