

Standard Hydraulic Valve

Urinal Flushing



This industry leading, hydraulic valve (STD) is an automatic urinal flush control valve, which easily attaches to the supply pipe of the urinal cistern. The valve prevents water wastage with a simple patented mechanism that requires no batteries or electrical supply.

It operates by only allowing water to flow to the urinal cistern whilst the washroom is in use. The valve is activated by short-term pressure drops, created by use of taps or WCs on the same supply. The valve naturally rests in a closed position; and when activated the hydraulic valve opens, allowing water to pass to the urinal cistern, until the water pressures on both sides of the valve are equalised.

This hydraulic valve also has an optional hygiene flush attachment for when washrooms are vacant for long periods of time, this ensures an automatic full flush approximately every 12 hours, to rinse the urinals and prevent washroom odours.

Key features and benefits

- **Water saving and sustainable** – reduce water consumption and washroom odours
- **Automatic urinal flushing** – for use with urinal cistern
- **Easy to install and maintain** – mount on the supply pipe to the urinal cistern
- **Fit and Forget** – quality and reliability
- **No batteries or electrical supply** – unique hydraulic mechanism
- **Industry leader**
- **Hygiene flush feature** – approx every 12 hours
- **Adjustable** – flow rate
- **Extended warranty** – 3 years
- **Support** – environmental building schemes
- **WRAS approved**
- **UK manufacturer**



3 YEAR
extended
warranty

Standard Hydraulic Valve

Hydraulic valve mechanism, no electrical supply or batteries required, 1/2" BSP (15mm).

Choosing the right valve for your application

There are two models in the range of Hydraulic Valves, each suited to different water supply pressure. The table below will help to specify the right model for your application:

Standard valve (STD) and Standard valve with hygiene flush (STDIF)

(Blue colour coded packaging)

Supply: Mains water pressures 0.5 bar to 6 bar or tank-fed systems above 5m head
Operating sensitivity: 15% of supply pressure

Low Pressure valve (LP) Low Pressure valve with hygiene flush (LPIF)

(Green colour coding packaging)

Supply: Tank-fed systems, 3m to 5m head
Operating sensitivity: 20% of supply pressure

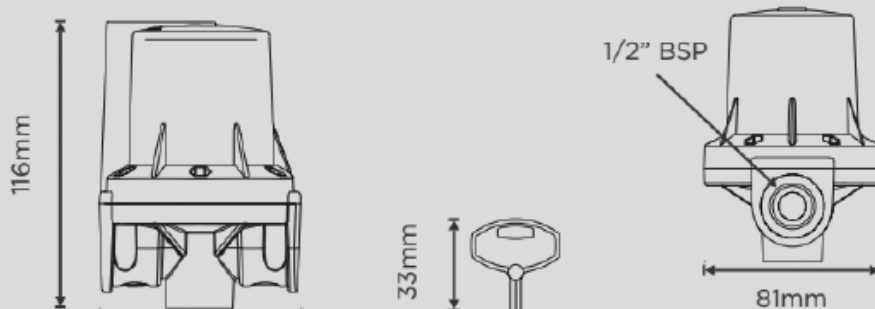

Measurements in millimetres (mm)

Installation

- Dimensions: 81mm W x 116mm H x 81mm D
- Pipe fitting requirements (inlet and outlet diameter): 1/2" BSP (15mm)

Regulatory and Compliance

- WRAS approved

Additional Parts / Optional Extras (additional costs apply)

- Hydraulic valve standard with hygiene flush attachment (STDIF)
- Hydraulic valve low pressure with hygiene flush attachment (LPIF)
- Hygiene flush attachment (HFA)

Cistermiser Limited

Unit 1 Woodley Park Estate, 59-69 Reading Road, Woodley, Reading, Berkshire RG5 3AN. Cistermiser is a subsidiary of Davidson Holdings Ltd. Cistermiser Ltd reserves the right to amend images and specification without prior notice.

