

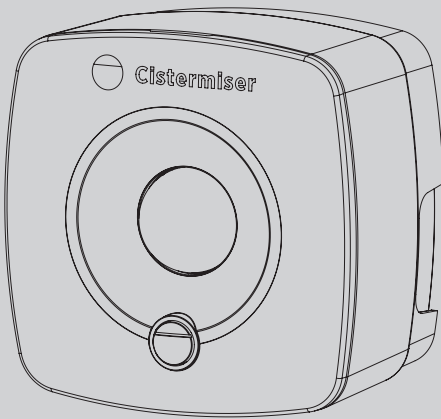

Cistermiser



Infrared Control Valve Installation Guide

Please keep this booklet
for future reference.

Installer, when you have read
these instructions please ensure
you leave them with the user.



Supplied Parts

- 1 Sensor Unit
- 2 Solenoid Valve
- 3 Mounting Bracket
(for cavity walls or ceiling tiles)
- 4 Remote Valve Plug & Gasket
- 5 Mounting Screws M3.5 x 40mm (x2)
- 6 Solenoid Mounting Screw M3 x 30mm

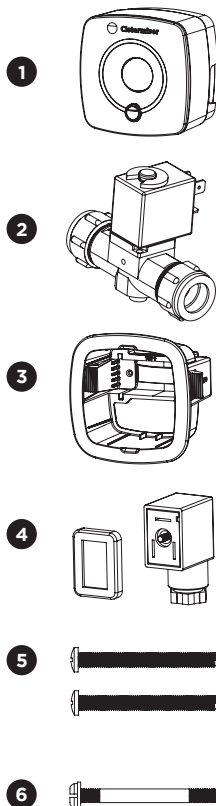

Not Supplied

2 core low voltage cable for remotely installed applications



Do not power unit until installation is complete and wiring carried out to BS7671 IEE regulations.



Isolate water supply before powering up.

FIT IN ACCORDANCE WITH WATER REGULATIONS

Under the water regulations, urinals should use no more than 7.5 litres per bowl per hour (10 litres for a single bowl).

1. Introduction

The infrared urinal flush control (IRC) valve automatically manages the supply of water to a urinal cistern.

The IRC is only to be used in conjunction with a cistern and is suitable for fixing to solid or cavity walls and false ceilings, or directly onto pipework.

The IRC sensor unit can be installed separately from the solenoid valve.

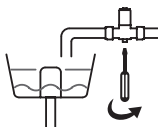

Adjust valve to fill in 30 min
(See Page 11 Section 6)

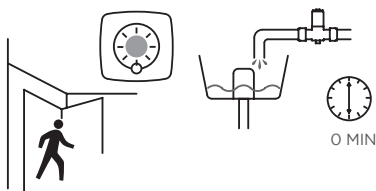

Occupancy detected -
valve opens for 30 min

After 25 min infrared sensor
looks again for occupancy

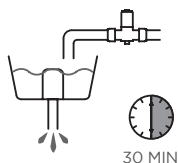

Cistern flushes when full

On detection of movement in the washroom, the IRC activates a 30 minute cycle allowing water to flow into the cistern.

During the last five minutes of the 30 minute cycle the sensor 'looks' for movement. If no movement is detected during these five minutes the valve will close. If the sensor detects movement a new 30 minute cycle is activated. If no movement is detected for 12 hours the IRC will activate a hygiene cycle.

2. Positioning

Front view



Side view

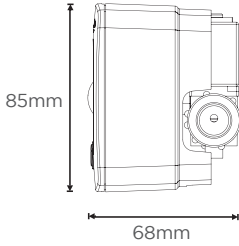

Back view

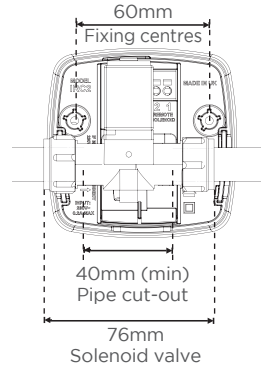

Pipe Mounted

(Battery-powered only)

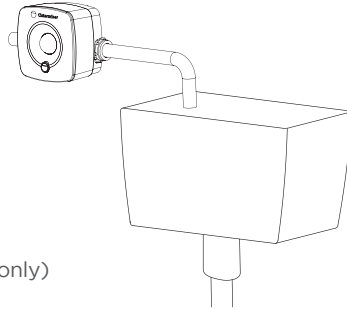

Remote Mounted

(Mains and/or Battery-powered only)

Solid Wall



Cavity Wall

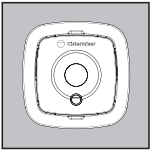

Ceiling

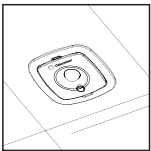

Cable: 1mm² (max 10m)

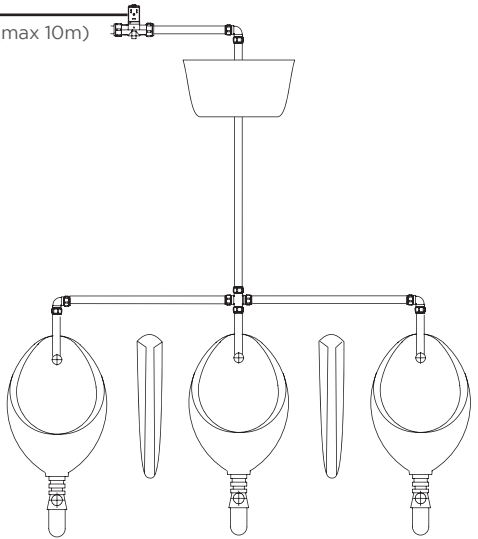

Sensor range

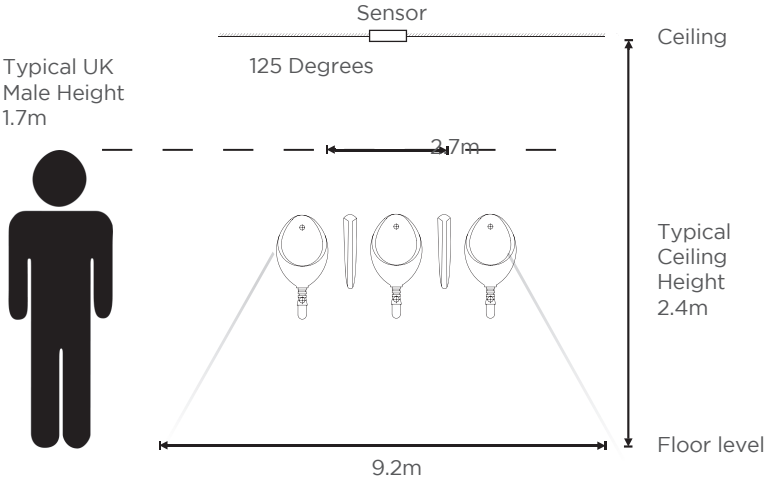

Maximum detection range 2.5m

NOT TO SCALE

3. Valve installation

Install the valve on the 15mm pipe feeding the cistern.

It is good plumbing practice to install an isolation valve upstream from the IRC valve.

NOTE: The valve should be positioned with the directional arrow pointing in the same direction as the flow of the water with the solenoid on top.

NOTE: There should be no restriction, such as a petcock or bibtap, after the valve.

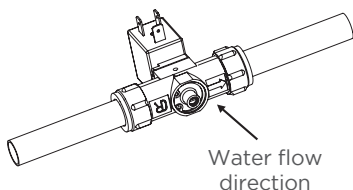
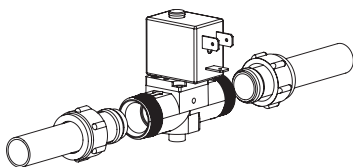

Changing the flow direction

In some installations the solenoid head may be facing the wall and the sensor cannot be fitted. You can turn the head around using the following action:

- Remove the solenoid coil clip (1)
- Lift the solenoid (2) and rotate the valve body (3)
- Replace the solenoid coil clip (1)

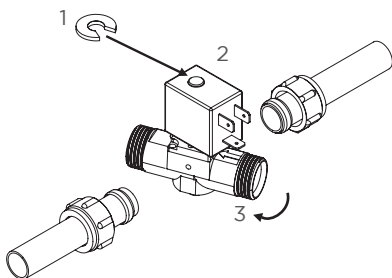

NOTE: Where one cistern feeds multiple urinal outlets, ensure the urinal outlets are evenly distributed and balanced so the cistern gives equal flush.

NOTE: One IRC is required for every cistern.

4. Sensor installation

Pipe Mounted

(Battery-powered only)

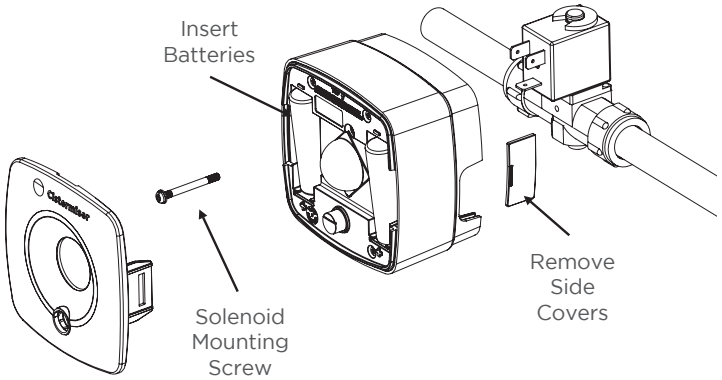
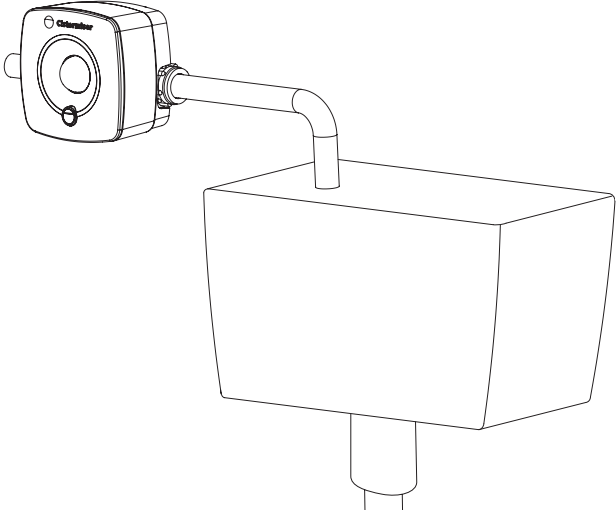

Remote sensor

(Mains and/or Battery-powered)

Connect cable from solenoid using the floating socket supplied. Make sure cable polarity is correct: 1 to 1 and 2 to 2.

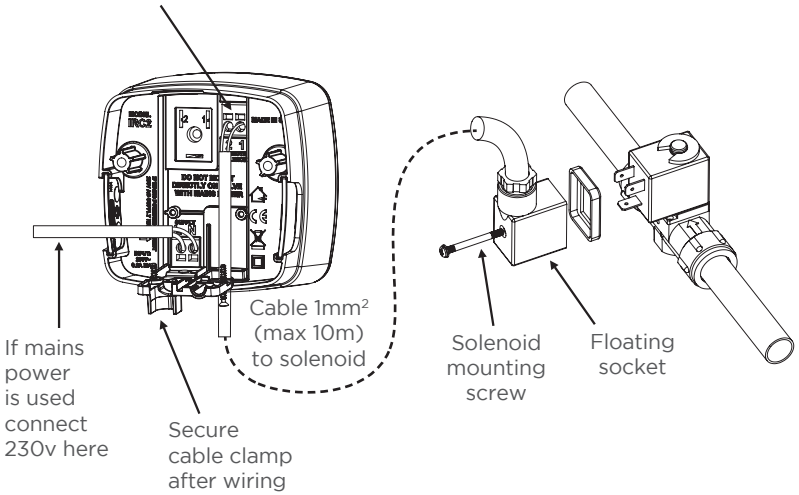

Solid wall/ceiling

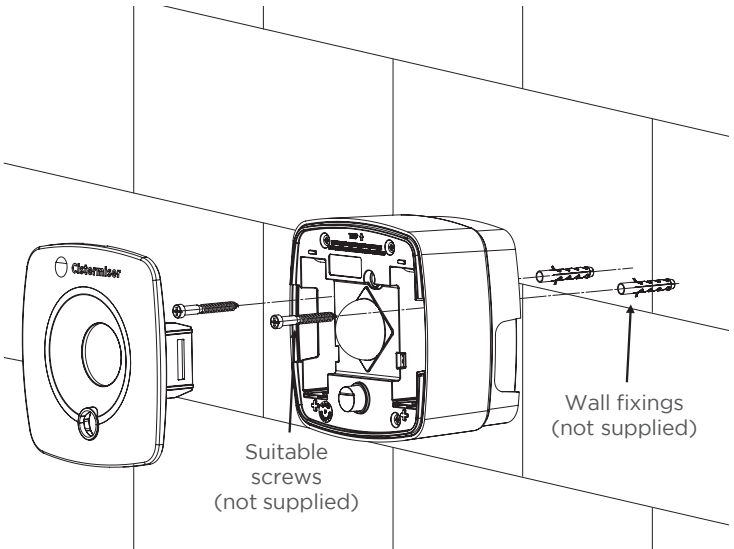

Cavity wall/ceiling

(Flush mounted)

Use mounting bracket to secure sensor in a cavity wall/ceiling.

Use
template
in box to
cut hole

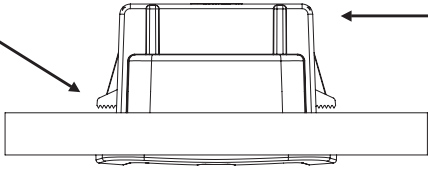

Mounting bracket

Wall/
ceiling/tile

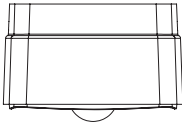

Sensor



Mounting screws
locate at the back
of the battery
compartment
(hand tight only)



Front cover

5. Power

Pipe mounted installations are Battery-powered only but Remote mounted installations can be Battery-powered and/or Mains-powered.

Battery

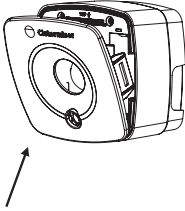

Remove front cover

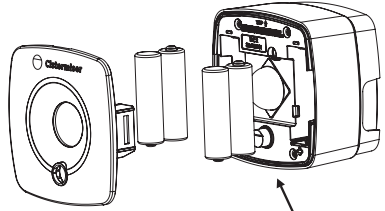

Insert 4 x AA Batteries

Mains

Mains cable specification:

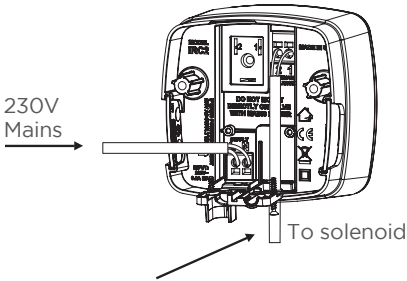

Nominal 230V \pm 10% AC 50 Hz

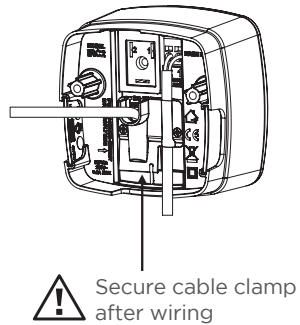

Solenoid cable specification:
CSA= 1mm²

Length 10m (max) from sensor
to solenoid



-  Do not mount a valve with Mains power directly onto pipework
-  When fitted directly onto pipework, only use Battery power
-  230V to be installed by a qualified electrician on a 3 Amp fused spur

6. Commissioning

Once all is installed, the flow rate will need to be adjusted to suit the particular installation.

Using the flow regulator on the bottom of the solenoid, you can either increase or decrease the flow of water. Ideally the cistern should flush once every 30 minutes.

Adjust the valve by turning the screw at the base of the brass valve body; clockwise to reduce the flow and anticlockwise to increase the flow.

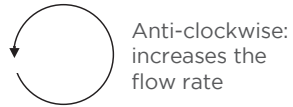
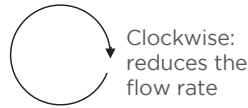
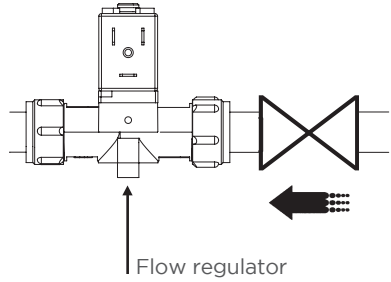

NOTE: Use the table below to set your cistern to flush once every 30 minutes. Adjust the flow through the valve so it takes the time below to fill a measuring cup to 100ml.

Cistern size	Time to fill 100ml
4.5L	40 sec
9.0L	20 sec
13.5L	13.5 sec

7. Test & economy modes

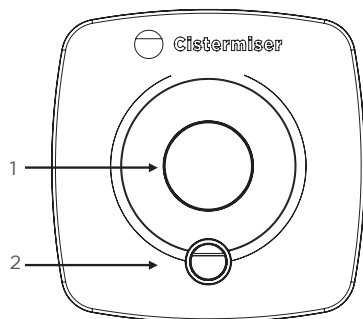

Test cycle

When the test button (2) is held down for over 2 seconds and less than 10 seconds then released the unit will go into Test mode.

It will first test the valve and the sensor will show amber, flashing each time the valve opens or closes. It will perform this action 5 times.

The unit will then test the sensor and only flash amber to confirm that it picks up any motion. Your movement around the room will highlight this is working.

The test cycle can be halted at any point by pressing the Test button and releasing straight away.

Switching sensor mode

Holding down the test button (2) for longer than 10 seconds will switch between Normal and Economy modes.

Whilst the test button is held down the sensor light (1) will show the mode that it is in:

- Solid green indicates Normal mode
- Flashing green indicates Economy mode



30 MIN

Normal mode

When a presence is detected the valve will remain open for 30 minutes. Whilst in operation a single green flash will be seen.



15 MIN +
30 MIN

Economy mode

When a presence is detected the valve delays opening for 15 minutes and then will open for 30 minutes. Whilst in operation a double green flash will be seen.

- If the sensor detects movement in the last 5 minutes of either mode's 30 minutes cycle it will reactivate a new cycle.
- The unit is supplied in Normal mode.
- When powered down the unit will remember the mode it is in.

NOTE: At any point that the test button is pressed and released the valve will close until there is movement in front of the sensor.

8. Usage advice and specification

Power

Mains Supply:	Nominal 230V \pm 10% AC 50Hz 20mA
Battery Supply:	6V from 4 x alkaline AA (LR6) batteries
Batteries (recommended):	Duracell Plus (Gold Top) MN1500 Capacity 2700mAh
Operating Life:	Up to three years with recommended batteries depending on washroom usage.

Solenoid valve

6V Latching Valve:	UK WRAS approved. One valve per sensor unit.
--------------------	--

Pressure range

Supply Pressure:	0.1 - 6.0 bar. Integral slow-fill flow regulator. If supply pressure is above 6.0 bar, fit a pressure reducing valve.
------------------	---

LED sequence

GREEN flash once every 3 seconds	Valve open - battery powered
GREEN flash once every 2 seconds	Valve open - mains powered
AMBER flash	Start up or Test cycle
RED flash	Low power
RED double	Fault

9. Frequently asked questions

Test mode does not function

No power	Ensure unit is powered. Change batteries if battery powered; ensure mains electrical power is functioning if mains powered.
Power supply fault	Disconnect one source of power and check by pushing the test button. When the sensor is mounted directly on the valve it should be battery powered ONLY. Also check remote wiring if sensor is remote from valve.

No water passing the valve

Water supply	Ensure water supply is turned on and reaching the valve. The valve is suitable for water pressures of 0.1 to 6.0 bar.
Blockage on the outlet pipe	If a petcock or bibtap has been fitted, ensure it is removed or fully open. Instructions state there should be no restriction after the valve.
Mesh filter blocked on inlet	Remove valve. Check to ensure filter on the inlet side of the valve is clear.
Flow regulator	Ensure the flow regulator is fully opened; when the valve is letting water run, turn down to the required flow rate.
High water pressure (above 6 bar)	Fit pressure reducing valve before the IRC valve.
No power	Ensure unit is powered. Change batteries if battery powered; ensure mains electrical power is functioning if mains powered.
Economy mode	The unit has been put into economy mode. See section 7 to reverse this.

Water is continuously flowing through the valve

User perception	Once activated the valve remains open for a period of 30 minutes and will reactivate if someone comes within the range of the sensor in the last five minutes of the 30 minute period. The valve appears to work continuously as long as someone is in the washroom.
No power	The power has failed while the valve is in the 'open' position. Ensure the unit is powered. Change batteries if battery powered; ensure mains electrical power is functioning if mains powered. Go through test cycle when power is restored.
Valve incorrectly fitted	Ensure the arrow on the brass body is pointing in the direction of water flow.

The valve remains shut when the room is occupied but opens at other times

Incorrect remote wiring	If the valve and sensor have been set up remotely, ensure the remote wiring is wired as follows: '1' to '1' and '2' to '2'. If you find the wiring is connected '1' to '2' and '2' to '1' then the valve is working in reverse.
--------------------------------	---

Water flow rate through the valve seems to be very slow

Flow regulation	Increase the flow rate by turning the flow regulator anti-clockwise until you reach your desired flow rate. Ideally it should fill the cistern once per activation and then flush. See Step 6 'Commissioning'.
Mesh filter blocked	Check to ensure filter on the inlet side of the valve is clear.

Water flow rate through the valve is fast and the cistern is flushing too frequently

Flow regulator

Decrease the flow rate by turning the flow regulator clockwise until you reach your desired flow rate. Ideally it should fill the cistern once per activation (i.e. every 30 minutes) and then flush. See Step 6 'Commissioning'.

I have just changed the batteries and there is no power to the unit

Battery orientation

Check battery orientation; ensure there is not excessive corrosion on battery terminals. Ensure batteries are a reputable brand.

Cistermiser product warranty and extended warranty

Cistermiser products are guaranteed for 12 months from the date of manufacture.

The guarantee is for faulty products and parts only: there is no labour warranty. If you believe your product is faulty, please either contact Cistermiser directly on **0118 969 1611** or at **support@cistermiser.co.uk**, with a photograph and the serial number, to help diagnose the cause of the problem.

The warranty on Cistermiser products can be extended within one year of date of manufacture, at no cost, to three years from the date of installation (see details on page 17).

Please make a note of the serial number and take a photograph of the installation before you leave site.

Commissioning checklist

IRC

<h1 style="font-size: 48px; margin: 0;">3</h1> <p style="font-size: 24px; margin: 0;">YEAR extended warranty</p>	<p>The warranty on Cistermiser products can be extended within one year of date of manufacture, at no cost, to three years from the date of installation. Once the valve has been installed, complete the product commissioning checklist below to demonstrate compliance with the installation instructions. Email a photograph of this completed form to warranty@cistermiser.co.uk or post to Cistermiser, Unit 1, Woodley Park Estate, 59-69 Reading Road, Woodley, Berks, RG5 3AN.</p>
--	--

Product serial number

Installation address

Installer's name

Telephone number

Email address

No.	Activity	Checked	Date
1.	Flush pipework prior to installation.	<input type="checkbox"/>	<input type="checkbox"/>
2.	Ensure the flow direction through the valve is correct.	<input type="checkbox"/>	<input type="checkbox"/>
3.	Ceiling mounted: ensure sensor range will cover urinal area.	<input type="checkbox"/>	<input type="checkbox"/>
4.	Electrical connections: ensure mains or battery power is connected. If mains powered, ensure mains adaptor is wired to 3A fused spur.	<input type="checkbox"/>	<input type="checkbox"/>
5.	Remote solenoid: check connections from sensor to solenoid are correctly wired. i.e. terminal 1 to 1 and terminal 2 to 2 between the sensor box and the solenoid.	<input type="checkbox"/>	<input type="checkbox"/>
6.	Set flow rate as described in section 6.	<input type="checkbox"/>	<input type="checkbox"/>
7.	Run the test cycle as described in section 7.	<input type="checkbox"/>	<input type="checkbox"/>

Davidson Holdings' brands

Salamander Pumps

Salamander is one of the UK's leading manufacturers of pumps for boosting water pressure for showers, bathrooms and whole house supply in domestic and small commercial tank-fed systems.

salamanderpumps.co.uk

Talon

Talon is the UK market leader in the manufacture and supply of plastic pipe clips, pipe collars and fixing plugs, plus a range of cover profiles for concealing pipework.

talon.co.uk



Keraflo

OUR WORLD IS WATER

Keraflo manufacture delayed action float valves, which provide an accurate and effective method of controlling the level of stored cold water in tanks both with and without raised float valve chambers. The range is used in domestic, commercial and industrial applications worldwide.

keraflo.co.uk



Combimate

GUARANTEED LIMESCALE PREVENTION

Combimate is a domestic limescale prevention device that prevents limescale build-up and soft water corrosion in combination boilers and other domestic hot water appliances.

combimate.co.uk

Cistermiser Limited

Unit 1, Woodley Park Estate, 59-69 Reading Road,
Woodley, Reading, Berkshire RG5 3AN

t: +44 (0) 118 969 1611

e: sales@cistermiser.co.uk

cistermiser.co.uk

A Davidson Holdings company

